



**AIR CAPS, FLUID ORIFICES AND NEEDLES AVAILABLE FOR THE JAGUAR SLP SPRAY GUN**

MODEL NO.	AIR CAPS	MAX INLET PRESSURE FOR HVLP (PSI)	APPROXIMATE CFM	AVAILABLE FLUID NOZZLES TIPS	NEEDLES / marking on needle
JAGUAR SLP	23-1308	29	13.5	33-0208 0.8mm (.022")	40-1308 (308)
	23-1310			33-0210 1.0mm (.040")	40-1310 (310)
	23-1312			33-0212 1.2mm (.046")	40-1312 (312)
	23-1313			33-0213 1.3mm (.052")	40-1313 (313)
	23-1314			33-0214 1.4mm (.055")	40-1314 (314)
	23-1315			33-0215 1.5mm (.059")	40-1315 (315)
	23-1317			33-0217 1.7mm (.070")	40-1317 (317)
	23-1319			33-0219 1.9mm (.075")	40-1319 (319)
	23-1322			33-0222 2.2mm (.086")	40-1322 (322)

Note: Air cap test gauges are available to confirm HVLP compliance.

Actual fluid nozzle and air cap combinations are determined by application (see page 4 for details)

# Operation and Maintenance Instructions for *Jaguar SLP* Gravity Spray Guns

## Operation

1. Connect air supply hose at handle of gun. 5/16" air hose x 25 ft. max. length is recommended. Also, only use CAT high flow quick disconnects and avoid using any restrictive fittings for the air supply to the gun.
2. Screw the paint cup onto the gun's gravity feed fluid inlet.
3. Fluid flow can be controlled using the fluid control knob, this restricts flow by limiting needle travel. It is best to control fluid flow by the proper selection of orifice size and use the fluid control knob to "fine tune flow rate".
4. Fan width can be adjusted using the fan control knob. Turning the knob clockwise narrows the fan.

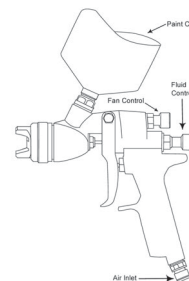

## Maintenance

IMPORTANT! Routine cleaning and maintenance is essential to insure proper gun operation. Several states prohibit spraying solvent into the atmosphere and require the use of covered gun cleaner.

1. If a gun cleaner is being used, connect and clean the gun in the gun cleaner according to the manufactures instructions.
2. If a gun cleaner is not being used:
  - Remove air cap and clean separately using clean solvent.
  - Clean the gravity feed cup thoroughly, then spray clean solvent through the gun until clean.

**NOTE: Gun disassembly is not recommended for normal cleaning and maintenance.**

## Gun disassembly and reassembly instructions:

Have repair kit # 10-105 available before gun disassembly.

### Disassembly

To remove nozzle carrier (4) and air cap adapter (6):

1. Remove the air cap (1), fluid tip (2), fluid nozzle body (3) and needle (16).
2. Remove needle seal cartridge (17).
3. Loosen locknut (11) and remove fluid inlet (12).
4. The fluid nozzle carrier (4) and air cap adapter (6) will now slide forward from the gun handle (13).

### Reassembly

1. Install new o-rings (8) and (7) on the air cap adapter (6).
2. Install air cap adapter (6) into gun body (13).
3. Install the locknut (11) and seal (10) onto the fluid inlet (12) as far as possible.
4. Install a new fluid inlet seal (9) into the recessed area on the nozzle carrier (4) inlet port.
5. Install seal (5) onto nozzle carrier, then slide the nozzle carrier (4) into the air cap adapter (6) as far as possible. Be sure the nozzle carrier extends into the hole at the back of the gun head. Install the needle seal cartridge (17) but do not tighten.
6. Rotate the nozzle carrier (4) until the fluid inlet port in the nozzle carrier is aligned with the threaded hole in the gun body (13). While in this position, insert the fluid inlet (12) and tighten firmly.
7. Tighten needle seal (17) to approx. 12 ft-lbs torque.
8. Tighten fluid inlet (12) to approx. 25 ft-lbs torque.
9. Tighten locknut (11) to approx. 33 ft-lbs torque.

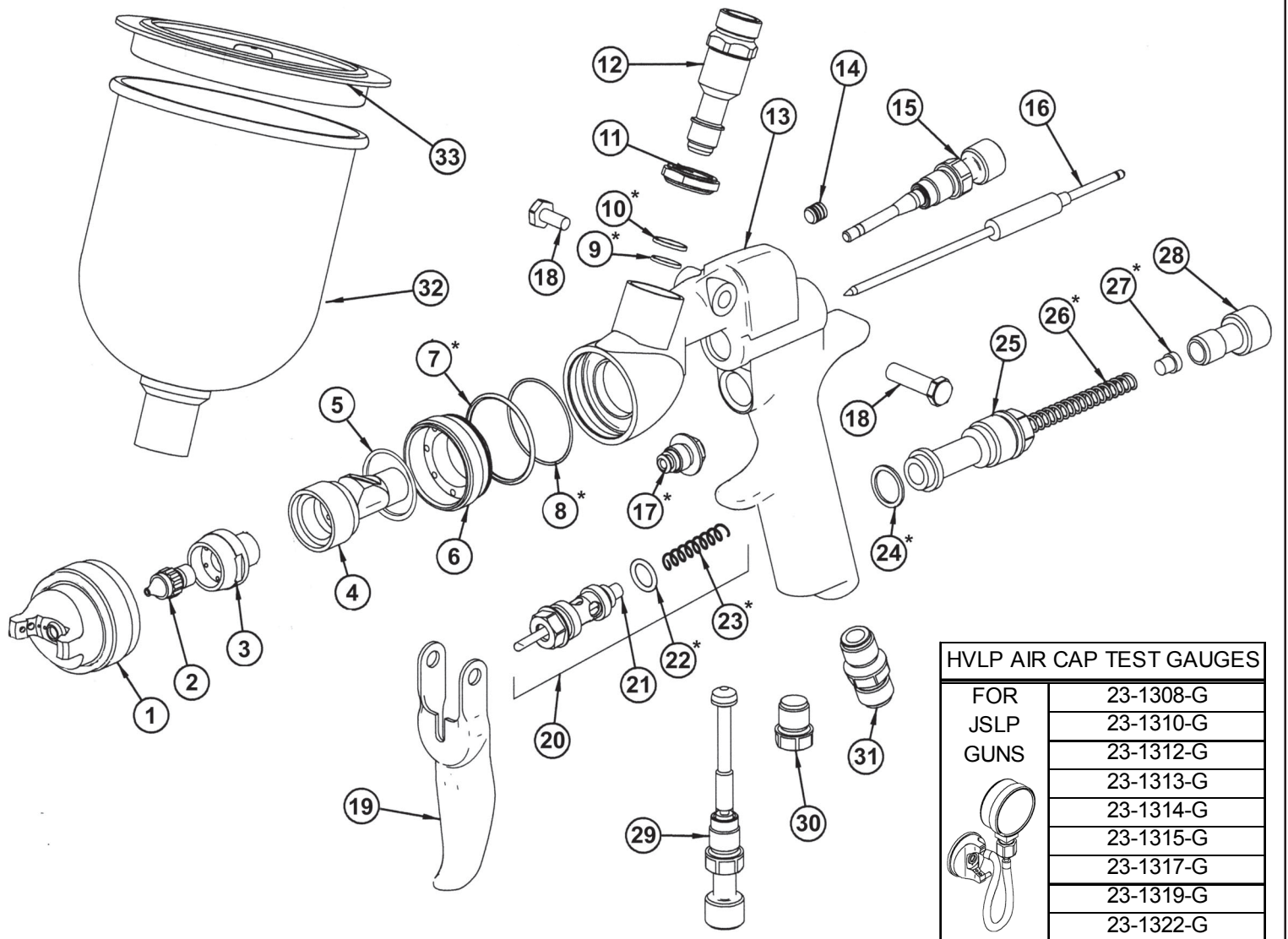

HVLP AIR CAP TEST GAUGES	
FOR	23-1308-G
JSLP	23-1310-G
GUNS	23-1312-G
	23-1313-G
	23-1314-G
	23-1315-G
	23-1317-G
	23-1319-G
	23-1322-G

ITEM NO.	PART NO.	DESCRIPTION	ITEM NO.	PART NO.	DESCRIPTION
1	See Air Cap Chart	Air Cap	18	60-1033	Trigger Pivot Screws
2	See Air Cap Chart	Fluid Tip	19	60-2101	Trigger
3	33-1202	Fluid Nozzle Body	20	60-1520	Air Valve Assembly
4	60-J31H	Nozzle Carrier	21	60-302	Air Valve Poppet
5	60-123	Seal	22	60-125	Seal*
6	60-34H	Air Cap Adapter	23	61-1003	Air Valve Spring*
7	98-8026	O-Ring*	24	60-119	Seal*
8	60-131	O-Ring*	25	60-201	Rear Bushing
9	60-130	Seal*	26	60-204	Needle Return Spring*
10	60-124	Fluid Inlet Seal*	27	60-205	Spring Seat*
11	60-118	Locknut	28	60-202	Fluid Control Knob
12	60-127	Fluid Inlet	29	60-1510	Inlet Air Control (Optional)
13	60-1119	Gun body	30	60-122	Plug
14	98-0109	Allen Plug	31	60-104	Air Inlet Fitting
15	60-1504	Fan Control Assembly	32	-	Gravity Cup (See Page 4)
16	See Air Cap Chart	Fluid Needle	33	-	Gravity Cup Lid (See Page 4)
17	60-1400	Needle Seal Cartridge*			

\*Indicates part included in repair kit # 10-105

# FLUID NOZZLE / AIR CAP SELECTION CHARTS

## *Jaguar SLP* - Gravity Feed Spray Guns

MATERIAL TYPE	FLUID ORIFICE x AIR CAP	MAXIMUM PATTERN WIDTH	CFM
<b>Very Thin</b> less than 16 sec. Zahn #2 inks , dyes, solvents, stains	0.8 mm x 1308 1.0 mm x 1310	12"	29 psi @ 13.5 cfm
<b>Thin</b> 16 to 20 sec. Zahn #2 lacquers, enamels, primers, sealers	1.2 mm x 1312 1.3 mm x 1313	12"	29 psi @ 13.5 cfm
<b>Medium</b> 21 to 30 sec. Zahn #2 automotive base coat enamels, primers epoxies, urethanes automotive clear coat	1.3 mm x 1313 1.4 mm x 1314 1.5 mm x 1315	12"	29 psi @ 13.5 cfm
<b>Heavy</b> over 30 sec. Zahn #2 heavy body primers high solid enamels high solid automotive coatings adhesives	1.7 mm x 1317 1.9 mm x 1319 2.2 mm x 1322	12"	29 psi @ 13.5 cfm

## KITS FOR *Jaguar SLP* GUNS

HVLP KITS	ORIFICE	AIR CAP	ORIFICE (TIP)	NEEDLE
<b>JK1308</b>	0.8	23-1308	33-0208	40-1308
<b>JK1310</b>	1.0	23-1310	33-0210	40-1310
<b>JK1312</b>	1.2	23-1312	33-0212	40-1312
<b>JK1313</b>	1.3	23-1313	33-0213	40-1313
<b>JK1314</b>	1.4	23-1314	33-0214	40-1314
<b>JK1315</b>	1.5	23-1315	33-0215	40-1315
<b>JK1317</b>	1.7	23-1317	33-0217	40-1317
<b>JK1319</b>	1.9	23-1319	33-0219	40-1319
<b>JK1322</b>	2.2	23-1322	33-0222	40-1322



### **CP-JSLP Includes:**

51-401 750cc Aluminum Gravity Cup  
 51-418 Gravity Cup Lid  
 52-300 Mini Regulator  
 98-0104 3/8" Socket  
 98-0112 Ratchet Wrench  
 60-8001 Gun Wrench  
 98-0113 Gun Cleaning Brush  
 51-430 Gravity Gun Hook  
 Air Caps and Needles shown on Page 1

CAT PACKS ALSO AVAILABLE WITH 3M PPS™

